



INSTRUCTION BULLETIN

No. 9014053
Machine: M20 / T20
Published: 12-2015
Rev. 02

NOTE: DO NOT DISCARD the Parts List from the Instruction Bulletin. Place the Parts List in the appropriate place in the machine manual for future reference. Retaining the Parts List will make it easier to reorder individual parts and will save the cost of ordering an entire kit.

NOTE: Numbers in parenthesis () are reference numbers for parts listed in Bill of Materials.

Installation instructions for **kit number 9014030 / 9014031**

SYNOPSIS:

This kit contains the parts needed to install the telemetry system on M20 / T20 machines. Please follow step-by-step instructions.

SPECIAL TOOLS / CONSIDERATIONS: NONE

(Estimated time to complete: 1 hour)

The IRIS (telemetry module) must be activated to complete this installation. The module will not function until it is activated. Call local IRIS expert for assistance activating the module after all telemetry components have been installed. Have machine serial number and IRIS module SIM number (located on back of IRIS control box assembly) ready when calling for activation.

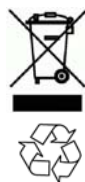

PROTECT THE ENVIRONMENT

Please dispose of packaging materials, used machine components such as batteries and fluids in an environmentally safe way according to local waste disposal regulations.

Always remember to recycle.

PREPARATION:

1. Start machine. Observe the LCD display for fault / diagnostic codes. All fault / diagnostic codes must be corrected before the IRIS system can be installed onto the machine.

FOR SAFETY: Before leaving or servicing machine, stop on level surface, turn off machine, and remove key.

2. Disconnect the battery cable from the machine.

WARNING: Always disconnect battery cables from machine before working on electrical components.

3. Open the front shroud.

INSTALLATION:

1. Remove the additional SIM label from the back of the control box (1) and set label aside in a safe place. The number on the SIM label will be needed for activating the machine. (Fig. 1)

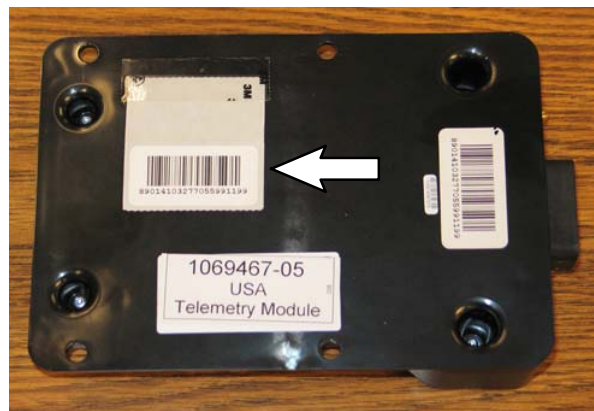

FIG. 1

2. Use the measurements in Fig. 2 to position the telemetry module (1) onto the front shroud and drill a 3.1750 mm hole through each existing hole in telemetry module and the inner surface of the front shroud. **Do Not** drill into the front surface of the front shroud.

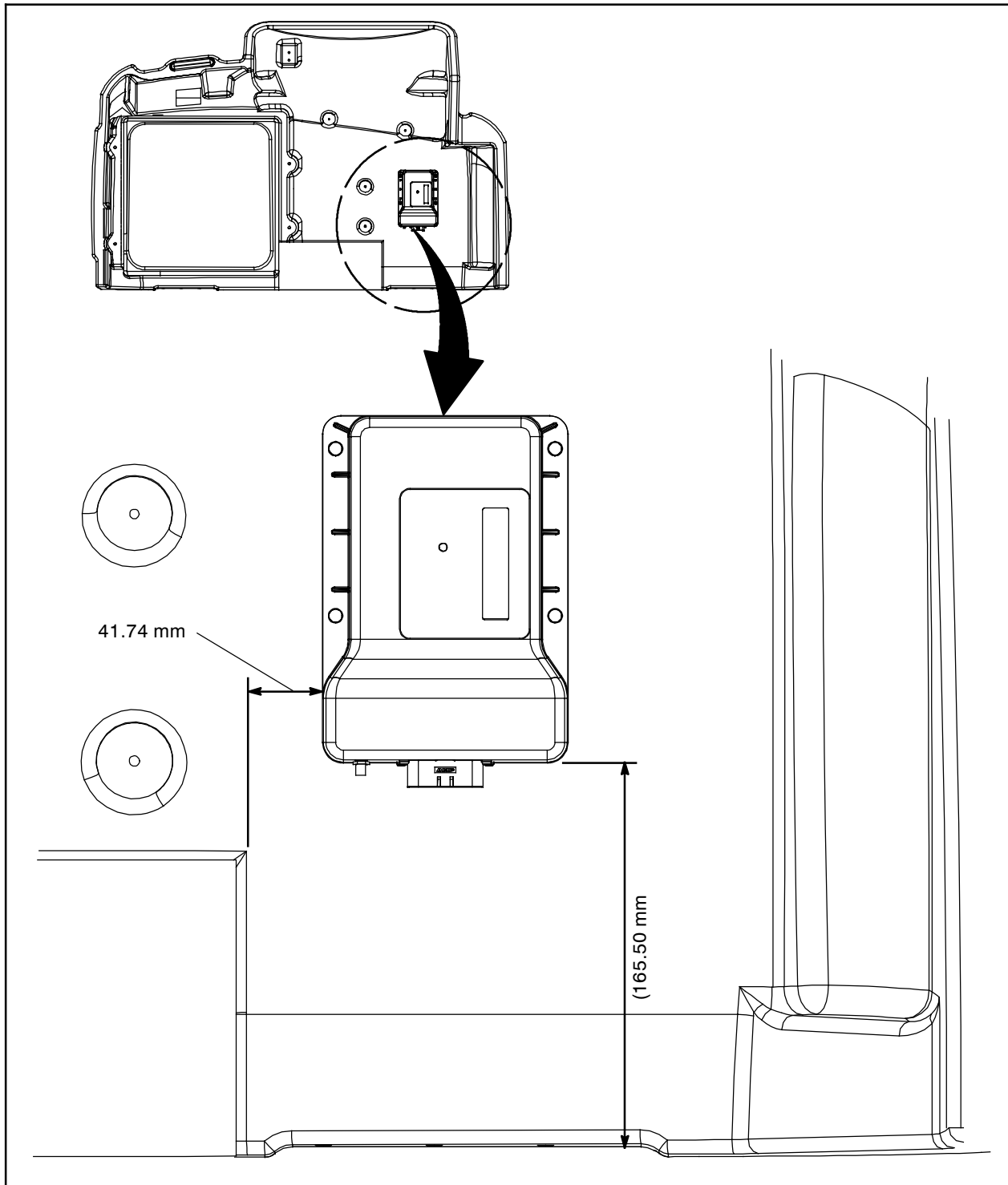

FIG. 2

- Remove the existing harness from the machine. Discard the removed harness. (Fig. 3)

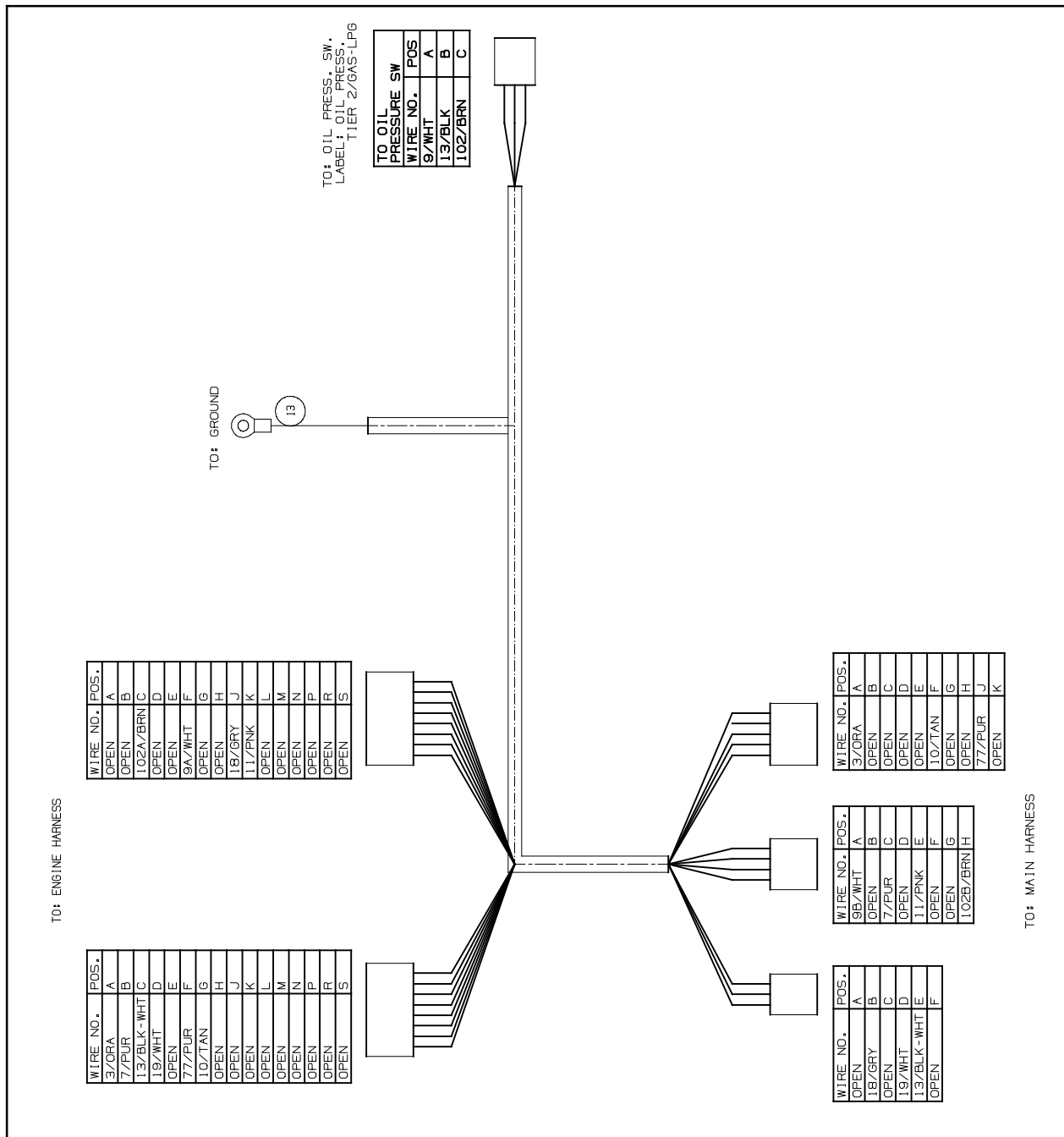

FIG. 3

4. Connect the telemetry harness (4) to the engine harness / main wire harness where removed harness was previously installed.
(Fig. 4 / Fig. 5)

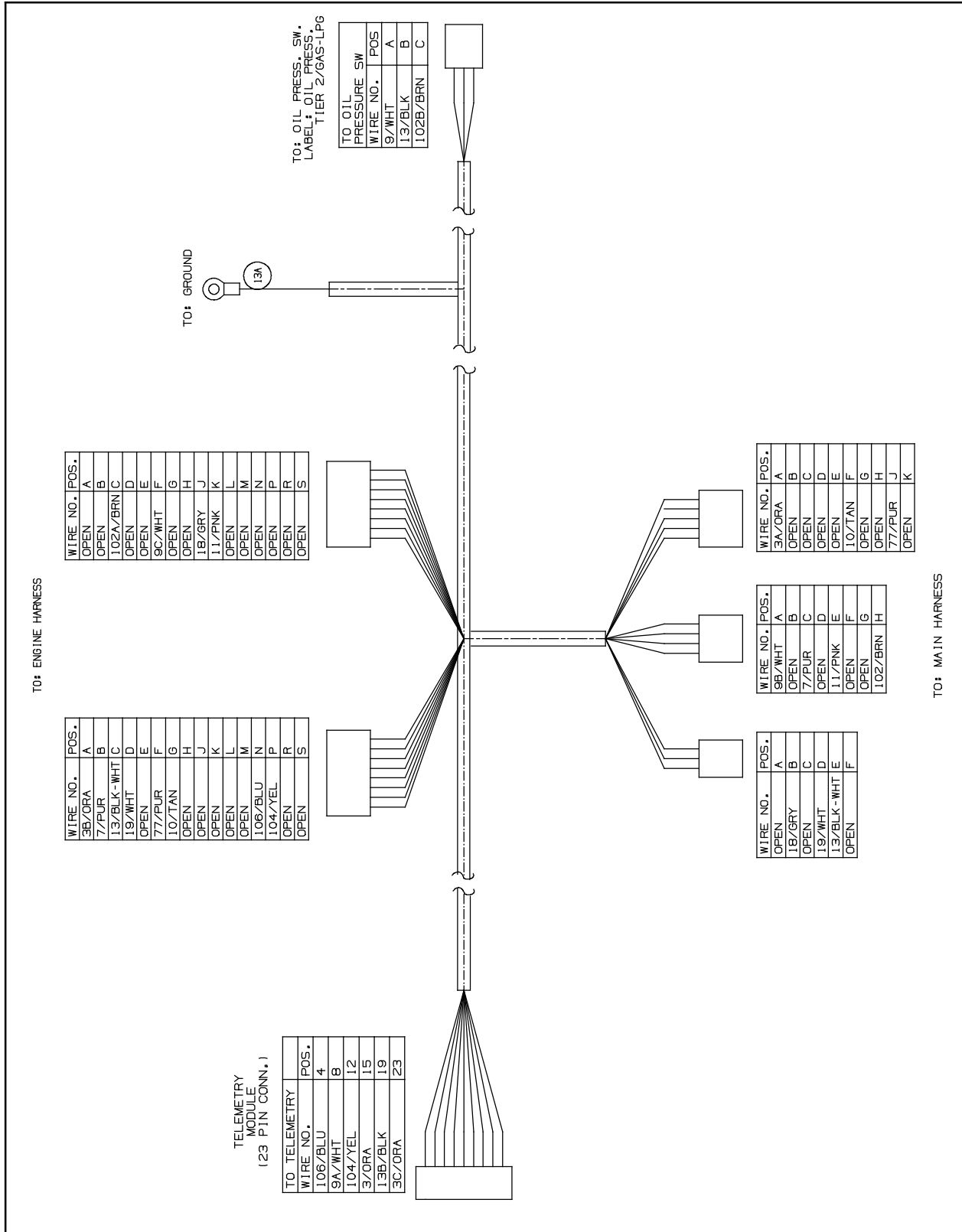

FIG. 4 - Gas / LP

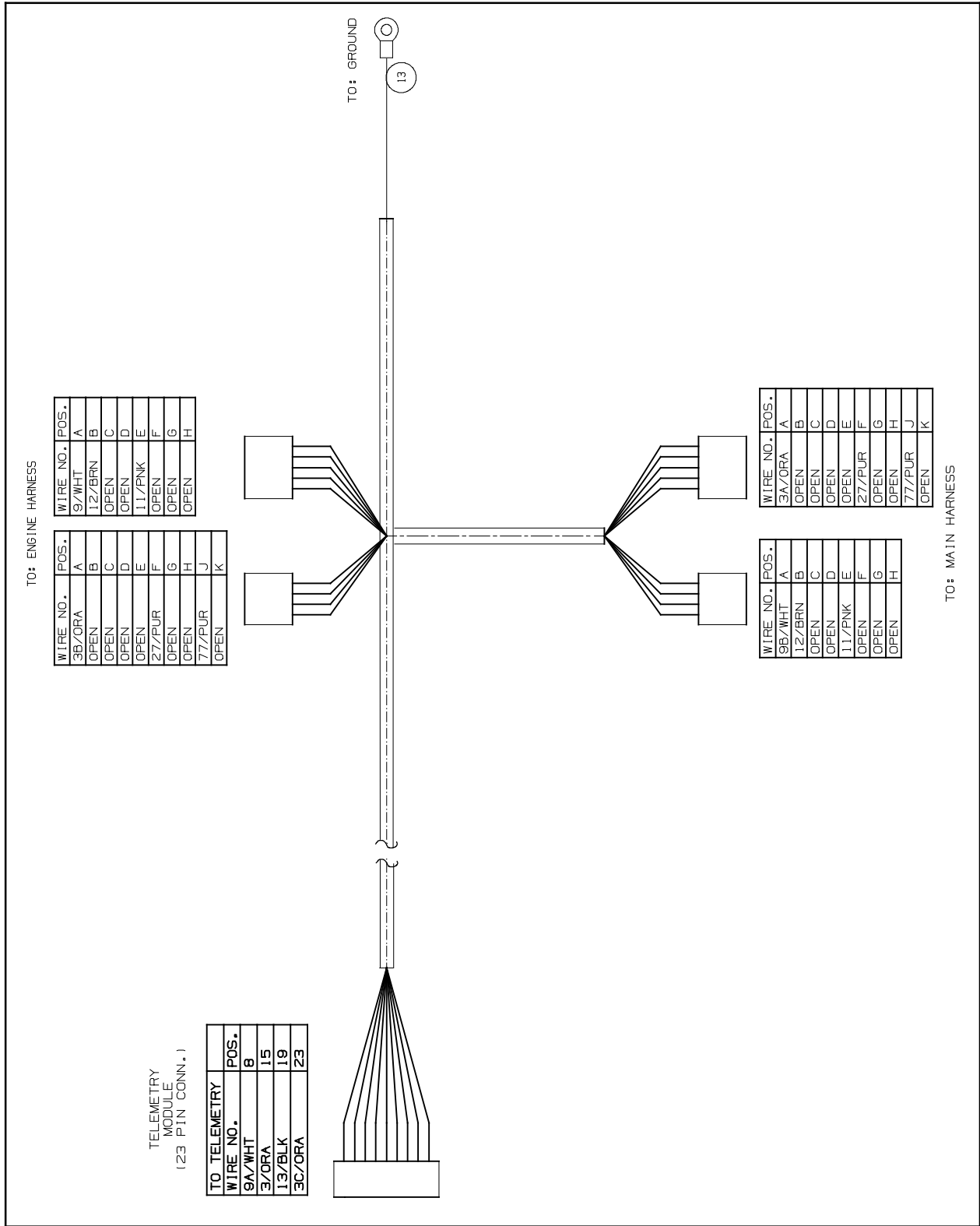

FIG. 5 - Diesel

5. Route the telemetry harness (4) along the main wire harness and to the front of the machine. Use several cable ties (6) to secure the telemetry harness to the main wire harness. (Fig. 6)

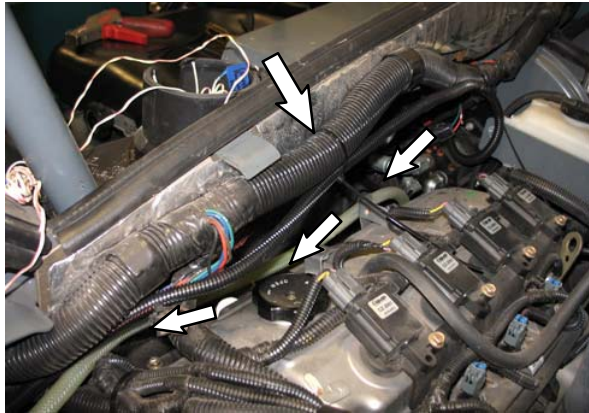

FIG. 6

6. Connect the antenna (7) cable and telemetry harness (4) to the telemetry module (1). (Fig. 7)

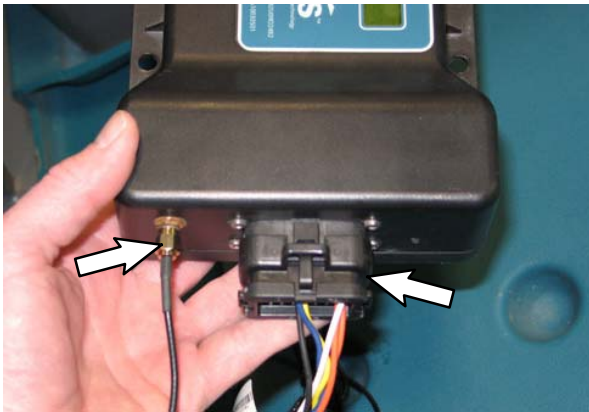

FIG. 7

7. Use four pan screws (2) and four flat washers (3) to install the telemetry module (1) onto the front shroud. (Fig. 8)

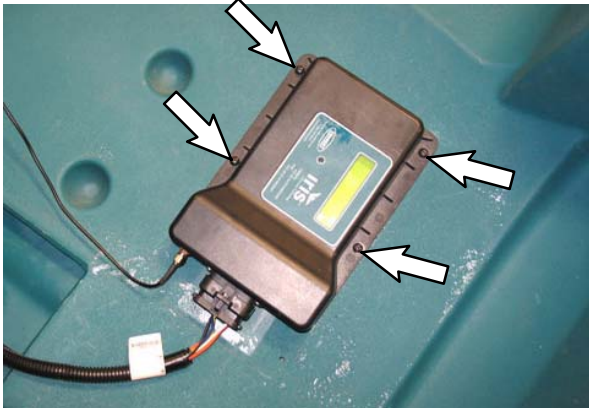

FIG. 8

8. Drill two 6.35 mm holes into the inner surface of the front shroud. **Do Not** drill into the front surface of the front shroud. (Fig. 9 / Fig. 10)

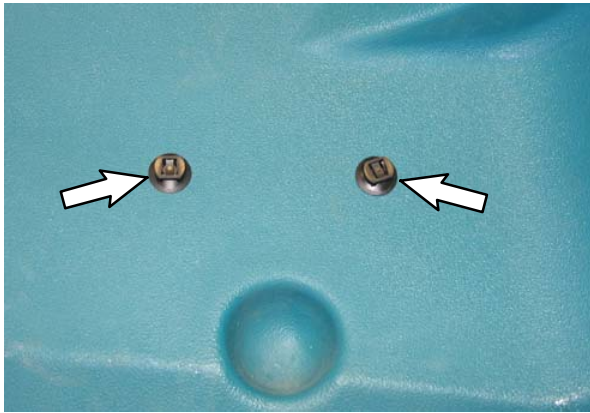

FIG. 9

9. Install two wire tie clips (5) for mounting the antenna (7) to the front shroud. (Fig. 9 / Fig. 10)

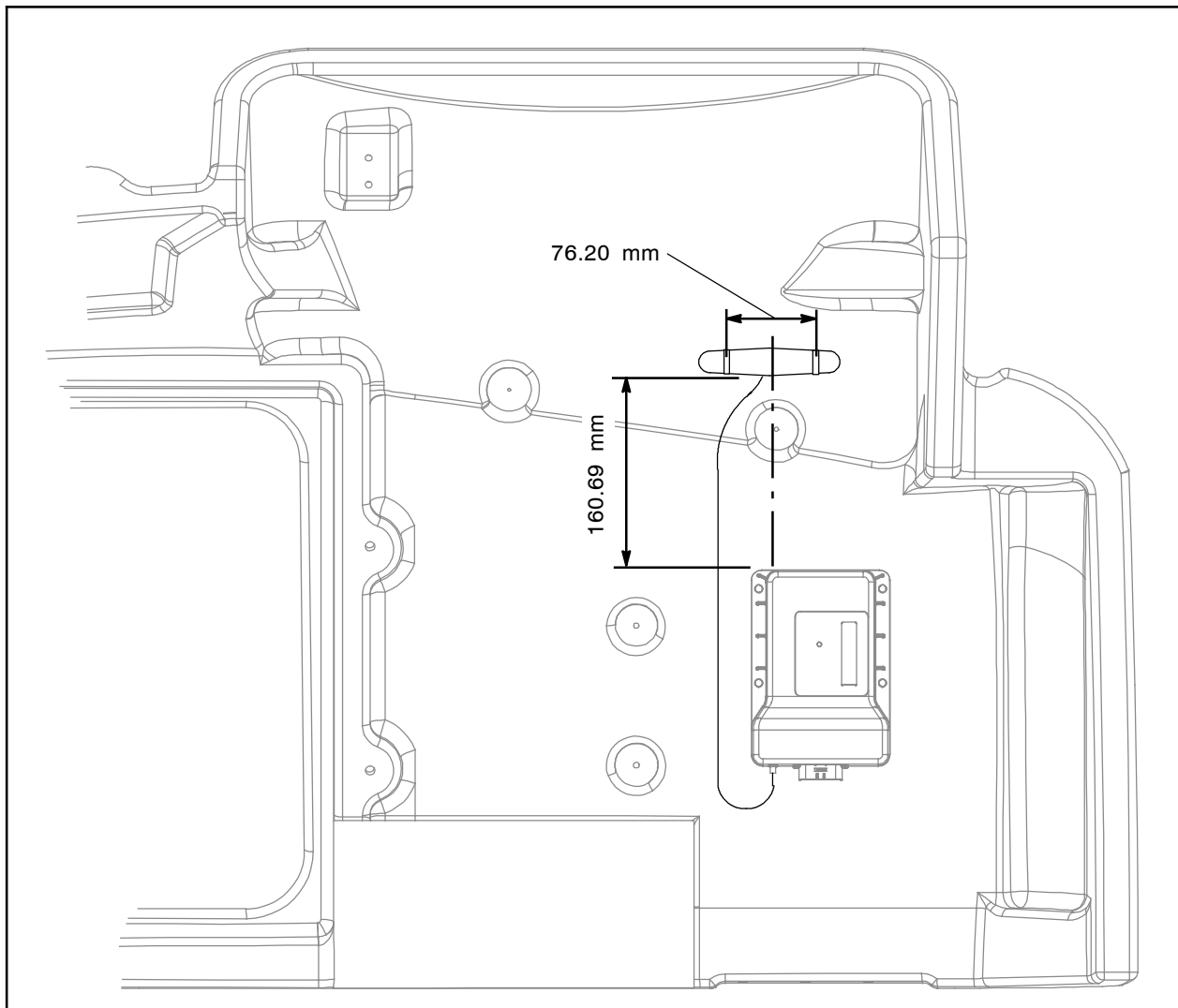

FIG. 10

10. Insert a cable tie (6) into each of the wire tie clips (5) above the telemetry module (1). (Fig. 11)

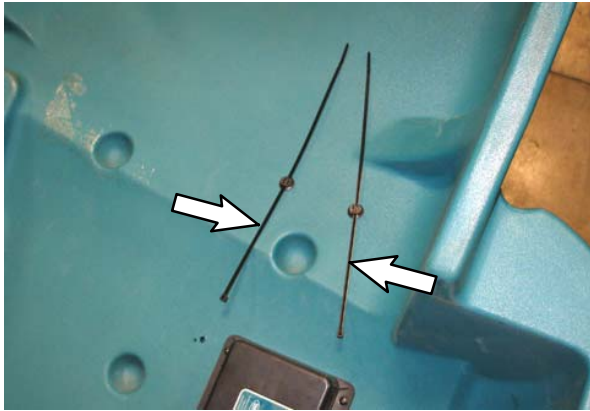

FIG. 11

11. Use the cable ties (6) to secure the antenna (7) to the front shroud. (Fig. 12)

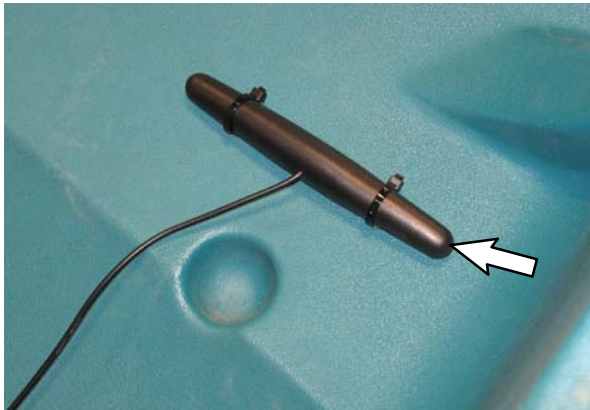

FIG. 12

12. Drill another 6.35 mm hole into the inner surface near the bottom of the front shroud, near the hinge. **Do Not** drill into the front surface of the front shroud. (Fig. 13)

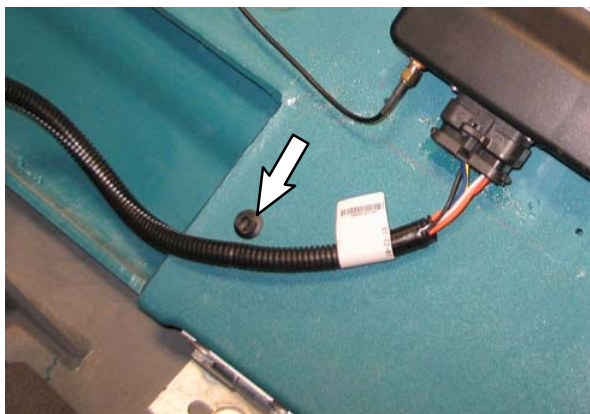

FIG. 13

13. Install another wire tie clip (5). (Fig. 11)

14. If necessary, bundle the antenna (7) cable and secure the bundled cable with a cable tie (6). (Fig. 14)

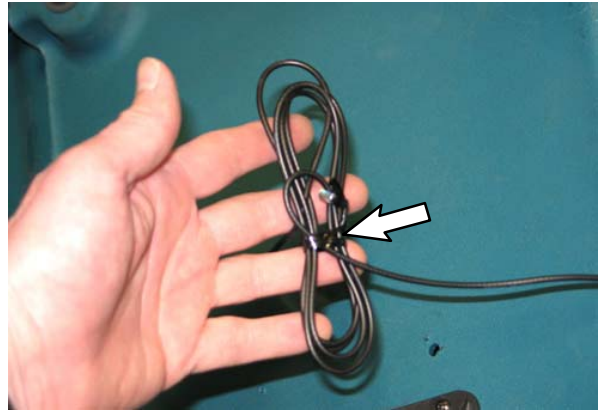

FIG. 14

15. Arrange the antenna (7) cable next to the telemetry module (1) and secure the telemetry harness (4) and antenna cable into the wire tie clip (5). (Fig. 15)

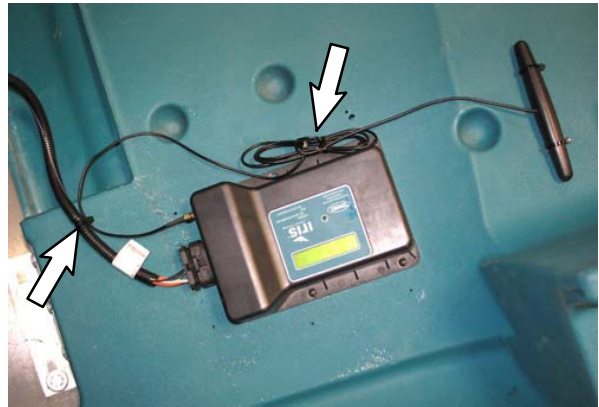

FIG. 15

16. Center the telemetry guard (8) over the telemetry module (1) and align the top edge of the telemetry guard with the top edge of the telemetry module. Drill a 3.1750 mm hole through each existing hole in telemetry guard and the inner surface of the front shroud. **Do Not** drill into the front surface of the front shroud. (Fig. 16)

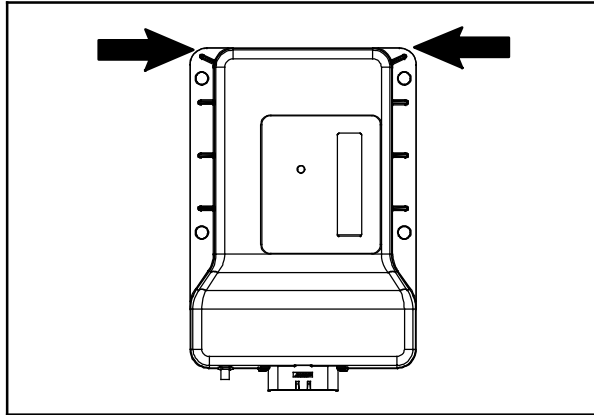

FIG. 16

17. Use four pan screws (2) and four flat washers (3) to install the telemetry module guard (8) over the telemetry module (1) and bundled antenna (7) cable. (Fig. 17)

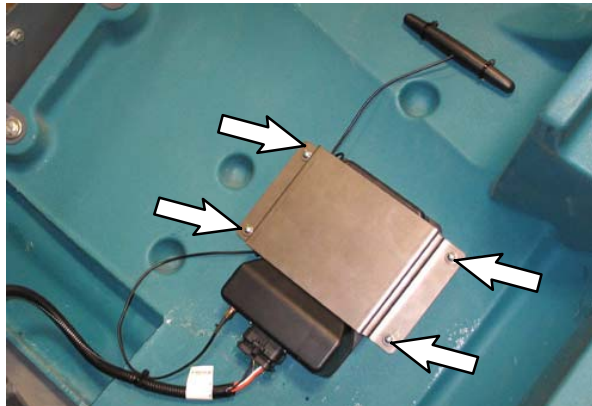

FIG. 17

18. Neatly bundle the telemetry harness (4) and secure bundled cable with a cable tie (6). Use two additional cable ties to secure the engine harness telemetry connector cable to the main wire harness. (Fig. 18)

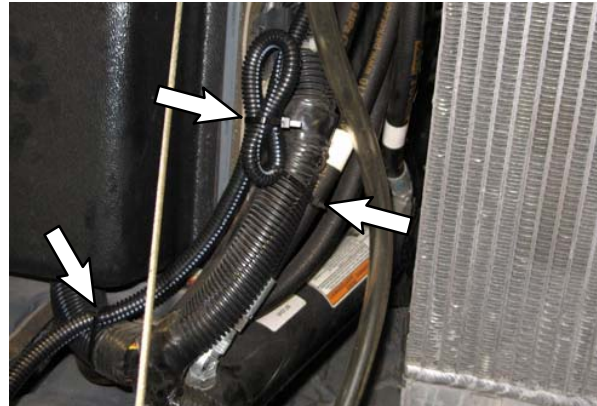

FIG. 18

19. Clean the area in the operator compartment where the telemetry label (9) is to be located and install the telemetry label onto the operator compartment. (Fig. 19)



FIG. 19

20. Reconnect the battery cables to the battery
21. Start and test the machine.
22. Activate the IRIS (telemetry module): Call local IRIS expert for assistance to activate the module. The IRIS telemetry system must be activated to complete this install. Have machine serial number and IRIS module SIM number ready when calling for activation.

NOTE: The IRIS (telemetry module) must be activated to complete this installation. The module will not function until it is activated. Call local IRIS expert for assistance activating the module after all telemetry components have been installed.

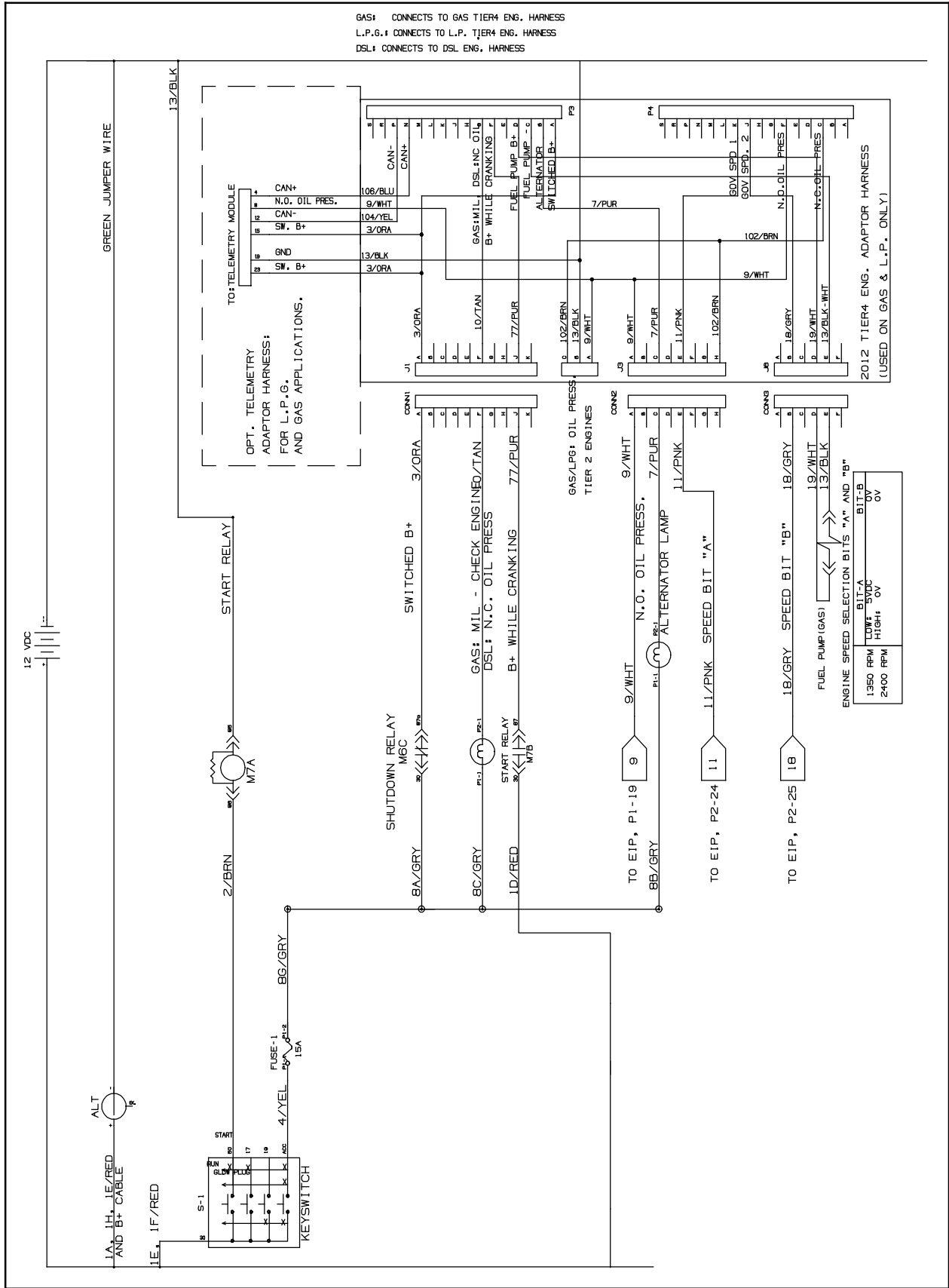

FIG. 20

**Bill Of Materials For Telemetry Kit, LPG, CI [M20 / T20, Intl/EU] - 9014030 /
Telemetry Kit, Dsl, CI [M20/T20, Intl/EU] - 9014031**

Ref.	Tennant Part No.	Description	Qty.
1	1070541	Control Box Assy, Telem [USA, 3G]	1
2	360943	Screw, Pan, Phl, 10- 14 X 0.75, F/ Plstc	8
3	19065	Washer, Flat, 0.19B 0.44D .05, PL, 08	8
4	1071641	Harness, Wire, Gas/LPG [MAKO, Telemetry]	1
4	1069876	Harness, Wire, Dsl [M20 / T20, Telemetry]	1
5	1210807	Wire, Tie [W/.25" Fir Tree Clip]	4
6	130773	Tie, Cable, Nyl, 11.0L, .14W, 3.0 Max. D	13
7	315724	Antenna, Telem, 18.0 IN [GPRS]	1
8	1217542	Guard, Module	1
9	1069580	Label, Opertnl, Telem [FCC/IC]	1

TENNANT COMPANY
P. O. Box 1452
Minneapolis, MN 55440-1452